

CONSTRUCTION OF A DUAL TUNED COIL

R. Stara^{1,2,3}, G. Tiberi² and M. Tosetti⁴

¹Dipartimento di Fisica, Università di Pisa, Pisa, Italy

²Imago7, Pisa, Italy

³Istituto Nazionale di Fisica Nucleare, Pisa, Italy

⁴IRCCS Stella Maris, Pisa, Italy

Take home messages.

- Choice of the coil design according to the available MR system and the anatomical region
- Choice of the material
- Coil construction live-show
 - Tuning of a DT coil
 - Matching of a DT coil
 - Decoupling by the mean of trap

Target audience.

MRCCommunity, with a particular attention to people not well skilled in RF engineering.

Outcome.

This live show has the ambitious goal of showing to people who are not expert in RF engineering/electronics the fundamental steps to be followed for a coil construction. The steps can be summarized as follows:

- 1) Choice of the coil design according to the available MR system and the anatomical region
- 2) Choice of the material
- 3) Coil construction
 - a. Tuning
 - b. Matching
 - c. Decoupling

We chose for this demonstration a coil with a simple design so that everybody, once back home, can promptly reproduce it. The coil we will construct is not only simple, but also usable, which means that it can be promptly plugged into the scanner.

Purpose.

We will give our live demo on Dual Tuned (DT) Transmit/Receive (Tx/Rx) coil. More in detail we show how to construct a coil comprising a single channel ¹H Tx/Rx coil plus a single channel ³¹P Tx/Rx.

Dual Tuned (DT) coils are often used for obtaining information related to other nuclei, e.g. ¹³C, ³¹P, ¹⁹F [1]. The reader is warmly encouraged to listen to the speakers of the previous section for a detailed overview of the DT coil theory/applications.

Methods.

As mentioned in the Outcome the first step to be followed in the construction process is the **choice of the coil design according to the MR system and the anatomical region**. The MR system available at our site is a 7T scanner equipped with two channels which can be either both for proton (formally speaking: ¹H, I and Q channel) or one for proton and one for Multi-Nuclear Spectroscopy (formally speaking: ¹H and MNS channel).

Concerning the anatomical region, we will focus on a human calf. In this context, the coil we have to construct must contain an adult human calf allowing for:

- Calf imaging
- ^1H spectroscopy
- ^{31}P spectroscopy

Thus, to meet the aforementioned requirements without adding any other hardware components between the MR system and the coil, we decided to adopt a solution which resorts to a coil comprising one channel ^1H Tx/Rx coil plus one channel ^{31}P Tx/Rx.

Keeping this solution in mind, we proceed in designing the coil layout, i.e. the support which will hold the coil. The support can be designed using any CAD package, as for example AutoCAD; the support has to be designed accordingly to the anatomical district, and has to be comfortable and easy-to-use. Fig. 1 shows the CAD of the support we realized. Note that we decided to leave 3 mm between the inner layer (where the coil circuits will lay) and the outer layer (where the calf will be positioned). Concerning the **Choice of the material**, we used for the support a polycarbonate structure obtained by 3D printing. The coil circuits consist of a printed circuit board (PCB) in FR4, board thickness 200 micron, copper thickness 17 micron. The other materials are listed in TABLE I, together with the equipment used for construction.

Tuning now to the **Coil construction**, we realize the ^1H Tx/Rx channel by etching a square loop having side length of 9 cm (see Fig 2).

Tuning of the ^1H loops is performed after measuring the inductance, which implies the following operation:

- a known capacitor has been added to the loop
- the correspondent resonance frequency has been measured through a VNA
- the inductance is determined by analytical calculation

Next, the loop has been tuned to 298.03 MHz, i.e. the Larmor frequency of ^1H at 7T. Next, the coil has to be matched: matching can be achieved either without load or with load, i.e. in the unloaded/loaded condition. A capacitive matching with load is performed here [2]: the Q factor is calculated through appropriate VNA measurements, and the corresponding resistance is derived. The matching capacitor can be determined by following a Smith Chart procedure [3].

The ^{31}P loop is realized by etching a square loop having side length of 11 cm (see Fig 2). The ^{31}P channels is decoupled from the ^1H by the insertion in the ^{31}P loop of a serial first-order trap circuit [4]. Tuning (at 120.6 MHz) and matching are performed following the same steps described for ^1H .

Once both loops were separately tuned and matched, decoupling has been performed using the trap circuit method [4]. This consists on adding an additional resonant circuit in series with one of the loops at the frequency of the other one. For example, if a resonant circuit tuned to 298 MHz is added in series to the ^{31}P loop it will behave as a high impedance for the ^1H , preventing the current from flowing. If needed, another trap circuit, tuned to 120.6 MHz, could also be added to the ^1H loop.

The trap circuit can be a constituted by an inductor in parallel to a capacitor (“first order”, as in [4]) or by a capacitor in parallel with a series LC circuit (“second order”, [1]). The advantage of a second-order trap with respect to a first-order trap is that it is possible to choose the desired impedance. In both cases, the inductor value has to be chosen to optimize the sensitivity at one of the two frequencies.

Once the value of inductor has been chosen, the values of the capacitors for the trap are easily obtained by solving the appropriate equations. The impedance of the trap can be measured using a calibrated fork probe. Fine tuning can be achieved slightly bending the wires of the inductor.

In our case, a first order trap circuit has been added to the ^{31}P loop. The values of inductor and capacitor are: $L=22$ nH, $C=10$ pF. After the insertion of the trap circuit, the ^{31}P channel needs to be retuned.

The S-parameters can be verified also through simulation. Simulations can be performed through full-wave electromagnetic codes (i.e. FEKO [<http://www.feko.info/>], which employs frequency-domain Maxwell equation solver or CST [<https://www.cst.com/>], which employs both frequency-domain and time-domain Maxwell equation solver). Simulation can be also used for evaluating B_1^+ maps (and, thus, homogeneity and coil efficiency) and the Specific Absorption Rate (SAR).

The feeding is done using a solid coaxial cable provided of a balun tuned to the required resonant frequency. All the corners of the coils are rounded: the curvature radius is 30 mm for the main loops and 2 mm for the end point of the strip. The circuit is covered by a protecting paint for avoiding corrosion.

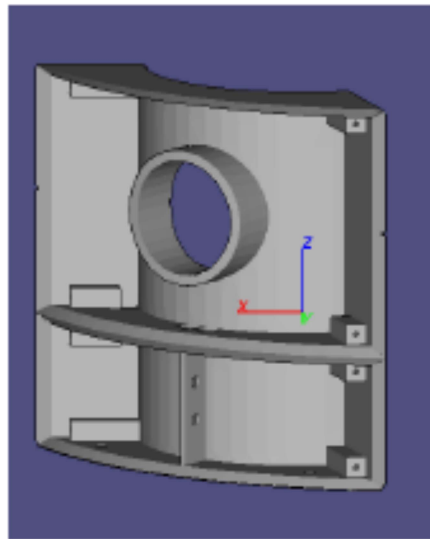

Fig 1. 3D CAD of the polycarbonate support

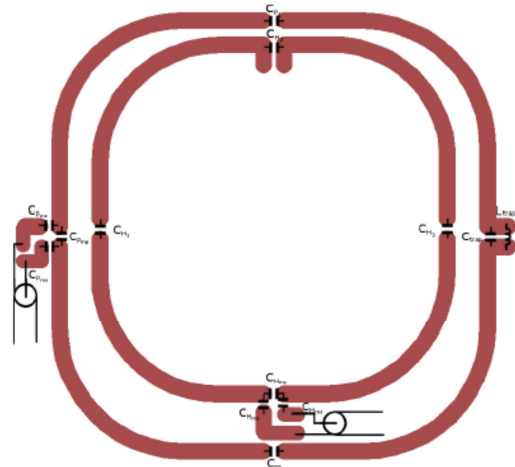
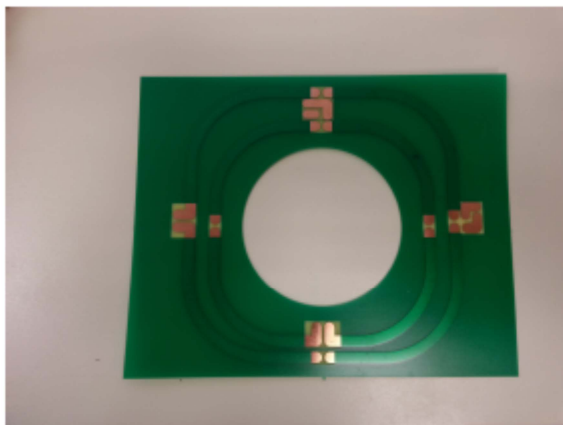

Fig 2. PCB without the lumped elements (left); schematic view of the RF circuits (right).

Results.

Workbench measurements. Fig 2, right shows a schematic view of the RF circuits, where in Fig 3 some pictures with details are given.

For the ^1H we obtained:

Q unloaded: 130

Q loaded (human calf): 14

Matching: -15 dB

Isolation: -23 dB

For the ^{31}P we obtained:

Q unloaded: 212

Q loaded (human calf): 17

Matching: -17 dB

Isolation: -18 dB

Simulations. Simulated results showed an excellent agreement with workbench measurements.

Scanner-based measurements. The coil, shown in Fig 4, has been integrated in the 7T MR system. B_1^+ maps and spectrum on both phantom and human calf will be shown during the live show.

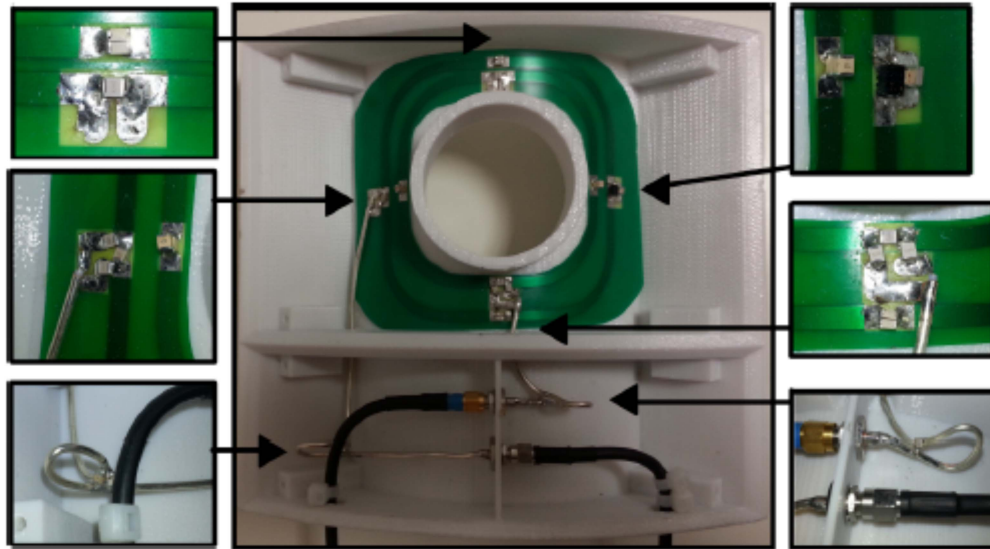

Fig 3. Pictures of the circuit with details



Fig 4. The DT coil

ITEM	MODEL	COMPANY
Non-magnetic chip capacitors	100B, 800B, 800A	ATC
Non-magnetic inductor	1812SMS-22NGL	Coilcraft
Cables (internal)	semirigid RG-402	Micro-coax
Cables (external)	RG-58	Belden
Network Analyzer	E5071C	Agilent
Solder Station	SmartHeat	OK international

TABLE I. Materials and equipment used for coil construction.

References.

1. Klomp DW, van de Bank BL, Raaijmakers A, Korteweg MA, Possanzini C, Boer VO, van de Berg CA, van de Bosch MA, Lujten PR. (31) P MRSI and (1) H MRS at 7T: initial results in human breast cancer. *NMR Biomed.* 2011 Mar 24
2. J. Mispelter, M. Lupu and A. Briguet, *NMR Probeheads for Biophysical and Biomedical Experiments: Theoretical Principles Practical Guidelines*, Imperial College Press, 2006.
3. P. Smith, *Electronic Applications of the Smith Chart*, 2nd edition, 1995, SciTech/Noble Publishing, Raleigh, North Carolina.
4. Alecci M, Romanzetti S, Kaffanke J, Celik A, Wegener HP, Shah NJ. J Practical design of a 4 Tesla double-tuned RF surface coil for interleaved 1H and 23Na MRI of rat brain, *Magn Reson.* 2006 Aug;181(2):203-11