

Optimisation of acquisition time for a dual calibrated FMRI protocol to measure absolute CMRO₂

Alan J Stone¹, Kevin Murphy¹, Ashley D Harris^{2,3}, and Richard G Wise¹

¹CUBRIC, School of Psychology, Cardiff University, Cardiff, United Kingdom, ²Russell H. Morgan Department of Radiology and Radiological Science, The Johns Hopkins University School of Medicine, Baltimore, Maryland, United States, ³F.M. Kirby Center for Functional Brain Imaging, Kennedy Krieger Institute, Baltimore, Maryland, United States

Target Audience: Researchers and clinicians interested in a quantitative measure of absolute cerebral oxygen metabolism.

Introduction: Dual calibrated FMRI (dcFMRI) is a recently introduced MR technique capable of measuring absolute CMRO₂¹⁻³ and is an extension of the calibrated BOLD methodology^{4,5}. To aid the implementation of dcFMRI in clinical and research scan protocols, it is necessary to produce reliable measures of absolute CMRO₂ in a short scan time. However, reducing scan time must be done carefully and it is important to establish that the parameter measurements are not compromised.

Theory: Here we investigate reducing scan times of an interleaved (INT) (Fig1a) and simultaneous (SIM) (Fig1b) hypercapnic-hyperoxic dcFMRI acquisition. The SIM approach has the added benefit of allowing BOLD signal model parameters, α and β , to be estimated³. To remove periods of transition and increase the success of data fitting, averaging of the CBF, BOLD and P_{Ei}O₂ time-series is performed over stable periods within each block. Fitting these block-averaged data-series with a BOLD signal model allows calculation of absolute CMRO₂³. Two approaches were used to investigate whether the amount of data used in fitting the signal model could be reduced with respect to the experimental designs shown in Fig1a and 1b. **Block averaging using varying window duration** - The effect of decreasing the number of time-points in each block averaged data-point on the final CMRO₂ estimate was investigated by incrementally decreasing window durations. This would correspond to experimentally shortening the duration of each period of the respiratory challenges. **Block averaged data-point resampling** - A data-point resampling approach was used to determine if fewer respiratory blocks could be used to shorten acquisition time and still produce reliable estimates of CMRO₂.

Method: 8 normal healthy participants (aged 24-39) were scanned using a 3T GE HDx MRI system. INT (Fig1a) and SIM (Fig1b) dcFMRI protocols were performed at rest in each subject. Details of the dual-echo ASL acquisition, pre-processing to produce CBF and BOLD time-series, end-tidal forcing equipment and fitting routines used to calculate absolute CMRO₂ can be found in Wise et al.³. Mean CBF and BOLD time-series in GM and P_{Ei}O₂ time-series were block averaged. For the INT design, block-averaging periods were calculated for the final 30s of each 60s respiratory block (baseline and HO) and 120s of each 150s block (HC). The final 30s of each 60s respiratory block was used to block average the SIM design. These were considered the 100% window durations. **Block averaging using varying window duration** - The averaging windows were reduced in duration by 10% increments, with all windows beginning at the centre of the respiratory block. Decreasing percentage size of the window meant fewer time points used for that average. **Block averaged data-point resampling** - For each subject the 100% block averaging windows produced BOLD, CBF and P_{Ei}O₂ data-points including 9 baseline, 2 HC and 4 HO during the INT design and 4 baseline and 14 HC-HO of varying levels during the SIM design. Using the time-based groupings, Fig1c, the required data-points were randomly sampled, for each subject, creating a manufactured CBF, BOLD and P_{Ei}O₂ data-series. The BOLD signal model was then fitted to the data-series to calculate absolute CMRO₂ in grey matter. This procedure was repeated 1,000 times for each subject, for each time-based grouping.

Results & Discussion: **Varying window duration** - Changes in group mean and standard deviation CMRO₂ are presented in Fig2a. The INT and SIM designs achieve group parameter estimates that agree well with those calculated using the full averaging windows at a reduced window duration of approximately 50%. Estimates calculated using the INT design remain stable for increasing window duration after this point. However group mean CMRO₂ calculated using the SIM design show some instability after this point. **Data-point resampling** (Fig2b) - Subject means were calculated from the 1,000 randomly sampled iterations at each time-based grouping and the group mean and standard deviation was then calculated from these means across subjects. The SIM design converges on a group mean, which deviates by only ~5% from group CMRO₂ calculated using the full 18mins of data-points, using ~9mins (1 baseline and 8 HC-HO) or more of data, whereas reasonable CMRO₂ estimates seem to be achieved at a time based grouping of 13.5mins for the INT design. However the effect of randomly choosing the HC block adds a level of variation to the group mean CMRO₂, as can be seen in Fig2b, and it is therefore suggested that reducing the acquisition time of the INT design is best done using shorter respiratory HC blocks rather than removing one of them, given that there were only two in the full design.

Conclusion: Using windows of varying duration to block average the BOLD, CBF and P_{Ei}O₂ time-series it was found that reliable CMRO₂ estimates were produced using window durations 50% of those currently employed in the interleaved design. This suggests reliable CMRO₂ measures, comparable to those made using all data-points available from the full 18 min scan, can be made with a total acquisition time of ~13 mins for the interleaved design. Using the same analytical approach on the simultaneous respiratory design it was found that reducing the duration of the blocks gave less stable results. However the data-point resampling routine suggests that a simultaneous experiment retaining the full duration of the respiratory blocks but incorporating only half of them, therefore lasting 9 mins, would be adequate.

References: 1. Bulte et al. NeuroImage. 2012,60: 582; 2. Gauthier et al. NeuroImage. 2012,60:1212; 3. Wise et al. NeuroImage. 2013,83:135; 4. Davis et al. PNAS. 1998,95:1834; 5. Chiarelli et al. NeuroImage. 2007,37:808;

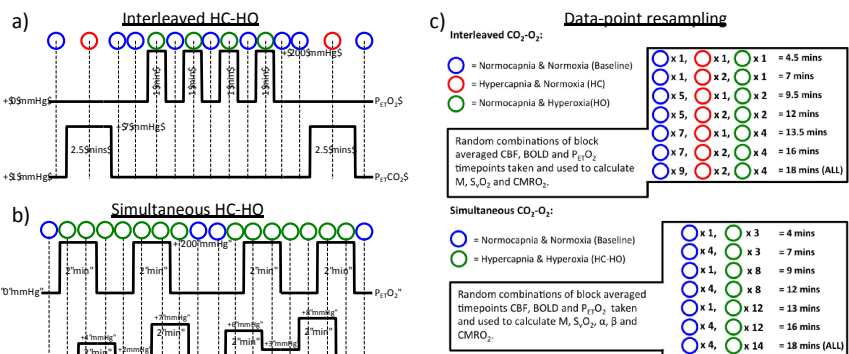

Figure 1: Fig1a shows the INT HC-HO design and Fig1b shows the SIM HC-HO. Fig1c shows the time-based groupings for the data-point resampling routine.

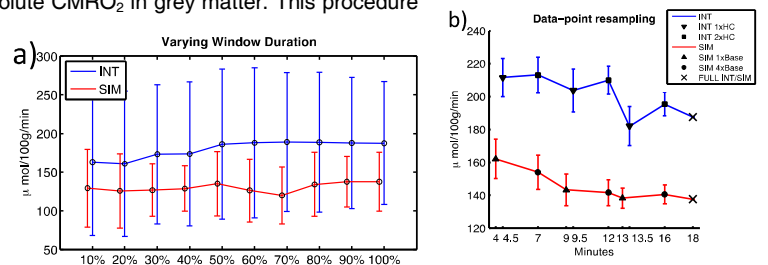

Figure 2: Group mean and standard deviation CMRO₂ are shown for the Block averaging using varying window duration analysis (Fig2a) and the Block averaged data-point resampling (Fig2b) alongside plots normalised to "full" acquisitions.