

Matrix Shimming for Whole Body Gradient coils

Derek A. Seeber¹, Kevin Koch², and Bernardo Ortega³

¹Engineering, GE Healthcare, Florence, SC, United States, ²ASL, GE Healthcare, Waukesha, WI, United States, ³Engineering, GE Healthcare, Apodaca, NL, Mexico

Introduction

A resistive shim coil set integrated into the gradient coil is an important tool for high-resolution imaging, especially brain imaging. The traditional high order shim coil is composed of spherical harmonic coils and requires the individual shim coils to have crossing points which will increase the radial build dimensions. The matrix array shim coil^[1-3] reduces the radial build dimension requirements and will permit the integration of the matrix array into a smaller radial space. The matrix array shim coil has the potential to offer increased static magnet field corrections over the traditional shim coil design for improved image quality. The shim coils are designed to minimize interactions with the magnet and gradient coils. A 24 channel matrix shim array coil was designed and integrated into a wide bore gradient coil to permit resistive shim corrections and improve image quality.

Matrix Shim Array Simulations

Computer simulations were executed to determine on optimal solution to generate higher order spherical harmonic terms while seeking to minimize the number of independent shim coils and reduce the number of independent shim coil drivers required. A matrix shim array of 6 coils around the circumference and 4 coils along the axis was determined to be the best solution in this design space. The configuration is shown in Figure 1, where the two rows per half of the coil are shifted relative to each other for improved performance. Each channel is configured into a "Figure-8" shape with a crossover to minimize interaction with the gradient coils and the magnet. The reduced interaction between the gradient and magnet should permit dynamic or slice by slice shimming with this configuration. The matrix array was used to simulate the effects on a clinical brain scan to demonstrate the performance of the new array. Figure 2 demonstrates the effect of the shim matrix on two slices near the

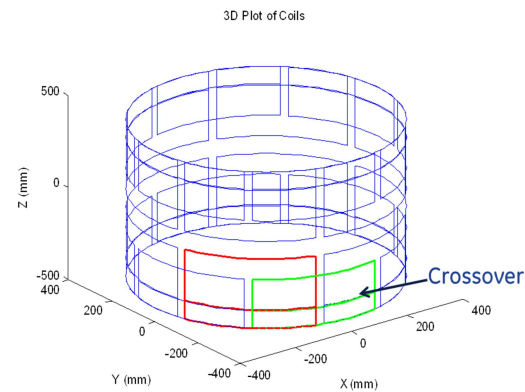

Figure 1. The matrix array shim coil is composed of 24 channels in a 6 x 4 array configuration. One coil is outlined in red and one coil is outlined in green forming the two different rows per half of the matrix shim coils.

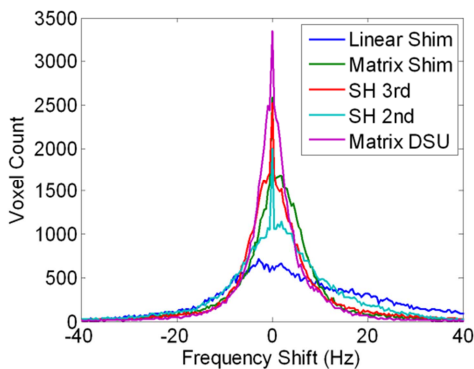

Figure 3. The 80% spectral width for the entire brain ROI reduces from 64 Hz for the linear shim, 32 Hz for the 2nd order harmonic system; 24 Hz for a 3rd order harmonic system and 22 Hz for a 24 channel matrix shim and further 15 Hz for dynamic shimming.

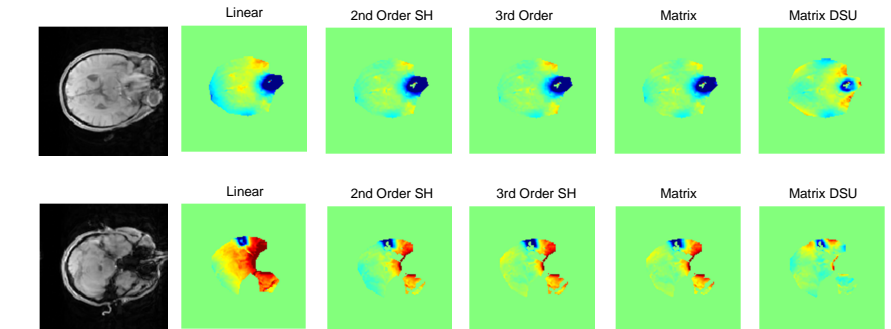

Figure 2. The magnetic field homogeneity is compared between a linear, gradient only correction, 2nd, 3rd and matrix array static and dynamic shim coils. The 80% width for the matrix array shim coil is superior to 3rd order corrections.

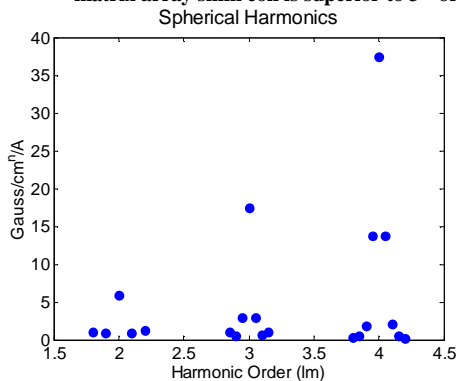

Figure 4. The maximum generated spherical harmonics produced by the matrix shim array are shown above. The array generates significant 3rd order terms and higher orders as well.

sinus cavity of the brain. The width of the field homogeneity is shown in Figure 3 for comparison demonstrating the improved shimming capability with the matrix shim array coil over a traditional 3rd order spherical harmonic shimming capability requiring only a fraction of the radial space of a tradition harmonic shim set. The equivalent spherical harmonics strength that can be generated with the matrix design is shown in Figure 4.

Matrix Shim Array Coil Integration

Each of the 24 circuit boards coils of the matrix array shim coil is constructed from a multi-layer Kapton circuit board enabling the shim coil board to be formed

to the correct radius for integration into the gradient coil. The matrix shim coils are placed between the inner and outer gradient coils and require ~3 mm of radial space. The shim boards are placed immediately on top of a gradient cooling circuit to provide addition cooling to the matrix array shim coils and provide temperature stability to the shim coils. The matrix shim coils are integrated with a Resonance Research Shim Power Supply (Billerica, MA) capable of dynamic changes of up to 10Amps per channel. An integrated matrix array shim set into a widebore gradient coil will be demonstrated with improved shimming capability over a traditional harmonic shim set.

1. Juchem, et al. "Dyanamic Shimming of the Human Brain at 7T". Concepts in Magnet Resonance Part B. Vol. 37B, P116-128, 2010.
2. Juchem, et al. "Magnetic field modeling with a set of individual localized coils". Journal of Magnetic Resonance. Vol. 203, P281-289, 2010.
3. Seeber, et al. "Matrix Shimming for Whole Body Gradient coils". ISMRM 2012, Melbourne, Australia.