

# Multi-Shot Diffusion-Weighted EPI with Readout Mosaic Segmentation and 2D Navigator Correction

D. Porter<sup>1</sup>, E. Mueller<sup>1</sup>

<sup>1</sup>Siemens Medical Solutions, Erlangen, Germany

## Introduction

A number of data correction schemes based upon navigator echoes (1,2) have been used to reduce artefacts from motion-induced phase variation in multi-shot, diffusion-weighted (DW) imaging. Most approaches have relied upon the assumption of a rigid-body model, which is not always valid in brain imaging due to deformation relating to CSF pulsation, leading to residual motion artefacts. A robust correction in the non-rigid-body case requires that the data from each shot be subjected to either a non-linear phase correction in image space or to the equivalent deconvolution procedure in  $k$ -space (3). This type of correction is most easily applied when a set of contiguous  $k$ -space points are sampled at each excitation, so that the Nyquist sampling condition is fulfilled for the specified FOV in both directions. One sampling strategy that meets this condition is that of the PROPELLER sequence (4), which has demonstrated the ability to acquire good quality diffusion-weighted images without the requirement for ECG triggering. Another acquisition scheme with contiguous sampling is multi-shot EPI with mosaic segmentation (5). If the mosaic segmentation is applied in the readout direction a considerable reduction in the EPI echo-spacing can be achieved compared to the single-shot case. This paper describes a readout-mosaic-segmented EPI sequence (RMS-EPI), which uses 2D navigator data to apply an image-based, non-linear phase correction, leading to a robust method for multi-shot DW imaging.

## Methods

The RMS-EPI pulse sequence diagram is shown in figure 1. After the diffusion preparation ( $G_D$ ) a sinusoidal EPI readout ( $G_R$ ) samples a segment of contiguous  $k_x$  sample points in the readout direction. A variable amplitude pre-phasing pulse (coloured blue) is applied to define an offset along  $k_x$ , which varies from one shot to the next. A blipped phase-encoding gradient ( $G_P$ ) is used to sample the complete  $k_y$  range at each shot. A second EPI readout is used to sample the central segment of  $k$ -space in the  $k_x$  direction, thereby forming the 2D navigator echo. During image reconstruction the navigator data are used to apply a non-linear 2D phase correction in the image domain. The sequence was implemented on a 1.5T Siemens Sonata system and the 2D navigator phase correction was applied during image reconstruction on the scanner. Images were acquired from healthy volunteers using the standard CP head coil, a FOV of 173x230mm, a slice thickness of 5mm, 21 slices,  $b=1000s/mm^2$  (AP direction), no ECG triggering, phase-encoding direction LR. Low resolution images were acquired using a matrix of 96x128, TR=3000ms, TE=69ms, EPI echo-spacing 220 $\mu$ s, one average, 9 shots, 2 prep scans, total scan time 33s. High resolution images were acquired using a matrix of 144x256, TR=4000ms, TE=80ms, EPI echo-spacing 280 $\mu$ s, 3 averages, 11 shots per average, 2 prep scans, total scan time 2min20s. Single-shot DW-EPI images were also acquired to match the low resolution protocol using a TR of 3400ms, a TE of 95ms, an echo-spacing of 700 $\mu$ s, phase-encoding direction AP, 4 averages, 1 prep scan, total scan time 17s.

## Results

Sample images from the study are shown in fig. 2. The images acquired with RMS-EPI were free from obvious motion artefact. The pattern of signal variation in the images was consistent with that in the single-shot images, suggesting that there is a low level of motion-related signal variation. As illustrated by the lower set of images in fig. 2, susceptibility artefacts were considerably reduced compared to the single-shot case.

## Discussion

These preliminary data indicate that the RMS-EPI technique with navigator-based, non-linear 2D phase correction is a robust approach to reducing motion artefact in DW multi-shot EPI studies. The method does not use multiple RF refocusing pulses in the data readout and is therefore insensitive to the signal modulations that can occur due to the failure of the CPMG condition in the presence of motion-induced phase errors. For the same reason, images can be acquired with well-defined slice profiles and low SAR. The RMS-EPI sequence also allows a relatively low TE for a given  $b$ -value, even when a full  $k$ -space acquisition is performed as in this study. A number of parameters are yet to be optimised, including the EPI echo-spacing, which should be small to minimise susceptibility artefact, but large enough to sample the number of  $k_x$  points required to apply the phase correction with a sufficiently high spatial resolution.

## References

1. Ordidge et al. *Magn. Reson. Imag.* **12**, 455-460 (1994).
2. Anderson & Gore. *Magn. Reson. Med.* **32**, 379-387 (1994).
3. Miller & Pauly. *Magn. Reson. Med.* **50**, 343-353 (2003).
4. Pipe et al. *Magn. Reson. Med.* **47**, 42-52 (2002).
5. Robson et al. *Magn. Reson. Med.* **38**, 82-88 (1997).

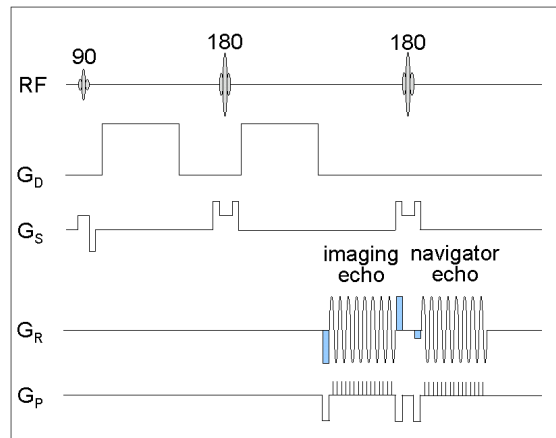

Figure 1: Pulse sequence diagram for DW readout-mosaic-segmented EPI (RMS-EPI) with a 2D navigator echo.

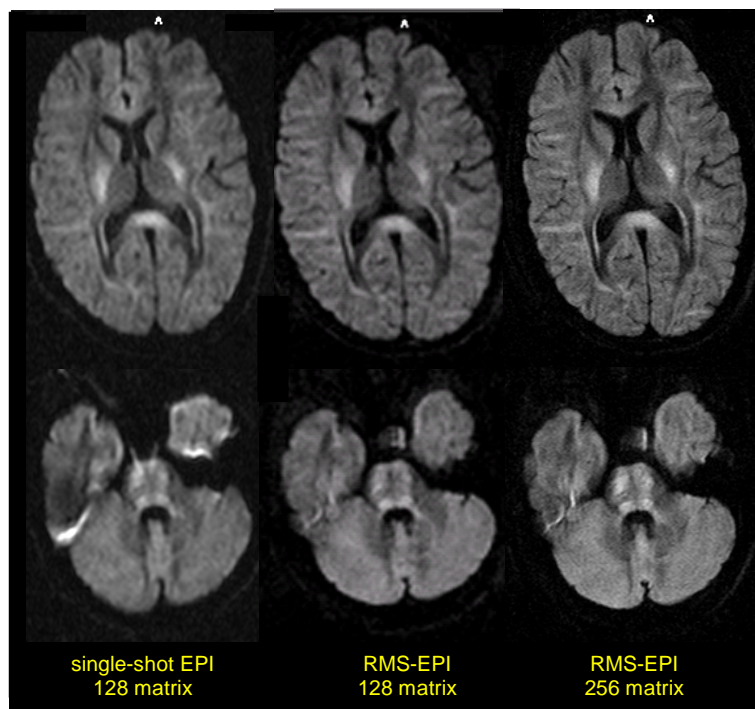

Figure 2: DW images acquired with single-shot EPI and readout-mosaic-segmented EPI (RMS-EPI) with a 2D navigator echo. Images acquired without ECG triggering.